

Elcometer 1615

Variable Impact Tester

Operating Instructions

elcometer® is a registered trademark of Elcometer Limited.

All other trademarks acknowledged.

© Copyright Elcometer Limited. 2010 - 2023.

All rights reserved. No part of this Document may be reproduced, transmitted, transcribed, stored (in a retrieval system or otherwise) or translated into any language, in any form or by any means (electronic, mechanical, magnetic, optical, manual or otherwise) without the prior written permission of Elcometer Limited.

A copy of this Instruction Manual is available for download on our Website via www.elcometer.com.

CONTENTS

Section	Page
1 About your Impact Tester	2
1.1 Standards	2
1.2 What the box contains (basic tester)	4
1.3 Kits of parts	5
2 Getting started	8
2.1 Identifying the parts	8
2.2 Mounting the instrument	8
2.3 Adjusting the guide tube	9
3 Assembling the parts	10
4 Assembling the kits	12
4.1 Assembling Kit A	12
4.2 Assembling Kit B	13
4.3 Assembling Kit C	14
4.4 Assembling Kit D	14
4.5 Assembling Kit E	14
4.6 Assembling Kit F	14
4.7 Assembling Kit G	15
5 Testing a specimen	16
5.1 Test procedure using Kit A	16
5.2 Test procedure using Kit B	17
5.3 Test procedure using Kit C	17
5.4 Test procedure using Kit D	17
5.5 Test procedure using Kit E	18
5.6 Test procedure using Kit F	18
5.7 Test procedure using Kit G	19
6 Maintenance	19
7 Technical specification	20
8 Spares and accessories	20

Thank you for purchasing this Elcometer 1615 Variable Impact Tester. Welcome to Elcometer.

Elcometer are world leaders in the design, manufacture and supply of inspection equipment for coatings and concrete. Our products cover all aspects of coating inspection, from development through application to post application inspection.

Your Elcometer 1615 Variable Impact Tester is a world beating product. With the purchase of this product you now have access to the worldwide service and support network of Elcometer. For more information visit our website at www.elcometer.com

1 ABOUT YOUR IMPACT TESTER

The Elcometer 1615 Variable Impact Tester is used to evaluate the resistance of a coating to impact (elongation, cracking or peeling).

The coated specimen is placed on top of a die and impact between the specimen and a hemispherical punch is produced by means of a falling weight. The specimen is removed from the tester and the damage to the coating caused by the rapid deformation of the metal is evaluated.

The tester is of heavy duty construction and is complemented by a range of test kits designed to suit the requirements of the test standards.

To maximise the benefits of your new Elcometer 1615 Variable Impact Tester please take some time to read these Operating Instructions. Do not hesitate to contact Elcometer or your Elcometer supplier if you have any questions.

1.1 Standards

The Elcometer 1615 Variable Impact Tester can be used in accordance with the following National and International Standards:

- ASTM D 2794:2004
- BS6496:1984
- BS EN ISO 6272-1:2004
- BS EN ISO 6272-2:2004
- DIN EN ISO 6272-1:2004
- EN 12206-1:2004
- EN 13523-5:2001
- ISO 6272-1:2002

- ISO 6272:1993
- ISO 6272-2:2002
- ISO 6272-1:2011
- ISO 6272-2:2011
- JIS K 5600-5-3:1999
- NF T30-017:1989
- ÖNORM EN ISO 6272-1
- QUALICOAT:2006
- SN EN ISO 6272-1:2004

Kits of parts are available which enable the tester to be used in accordance with these test standards. The appropriate kit of parts must be ordered in addition to the basic tester. The kits of parts are described in the paragraphs which follow and the contents of each kit are shown on the drawing included with the kit.

1.2 What the box contains (basic tester)

- Base plate
- Guide tube supporting arm
- Guide tube
- Release collar (fitted to guide tube)
- 4 mm hexagonal wrench
- Magnifier, 10x
- Operating instructions

Your Elcometer 1615 Variable Impact Tester is packed in a cardboard and foam package. Please ensure that this packaging is disposed of in an environmentally sensitive manner. Consult your local Environmental Authority for further guidance.



1.3 Kits of parts

Kit A (optional)

To meet the requirements of the following standards:

ISO 6272:1993	EN 13523-5:2001
JIS K 5600-5-3:1999	DIN EN ISO 6272-1:2004
SN EN ISO 6272-1:2004	ÖNORM EN ISO 6272-1:2006

- Falling indenter with handle, stop key and a punch (20 mm) (total mass = 1 kg).
- Die (27 mm) with fixing screw
- Specimen clamp with two fixing screws
- Hexagonal wrench, x2 (3 mm, 4 mm))
- Stop collar

Additional 1 kg weights are available as an optional extra - see “Spares and accessories” on page 20.

Kit B (optional)

To meet the requirements of the following standards:

ISO 6272-2:2002	ASTM D 2794:2004
QUALICOAT:2006	BS EN ISO 6272-2:2004

- Weight with handle (1 kg)
- Static indenter with handle and punch (15.9 mm)
- Punch (12.7 mm)
- Die (16.3 mm) with fixing screw
- Hexagonal wrench (3 mm)

Kit C (optional)

To meet the requirements of the following standards:

EN 12206-1:2004	BS6496:1984
ASTM D 2794:2004	

- Weight with handle (2 lb)
- Static indenter with handle and punch (15.9 mm)
- Die (16.3 mm) with fixing screw
- Hexagonal wrench (3 mm)

Kit D (optional)

To meet the requirements of the following standards:

ISO 6272-1:2002

BS EN ISO 6272-1:2004

- Falling indenter with handle, stop key and punch (20 mm) (total mass = 1 kg).
- Die (27 mm) with fixing screw
- Specimen clamp with two fixing screws
- Hexagonal wrench, x2 (3 mm, 4 mm))
- Stop collar

Kit E (optional)

To meet the requirements of the following standards:

NF T30-017:1989

- Falling indenter with handle and punch (23 mm) (total mass = 400 g).
- Die (22 mm) with fixing screw
- Hexagonal wrench (3 mm)

Kit F (optional)

To meet the requirements of the following standards:

ISO 6272:1993

EN 13523-5:2001

JIS K 5600-5-3:1999

DIN EN ISO 6272-1:2004

SN EN ISO 6272-1:2004

ÖNORM EN ISO 6272-1:2006

ISO 6272-2:2002

ASTM D 2794:2004

QUALICOAT:2006

BS EN ISO 6272-2:2004

- Falling indenter with handle, stop key and a punch (20 mm) (total mass = 1 kg).
- Weight with handle (1 kg)
- Static indenter with handle and punch (15.9 mm)
- Punch (12.7 mm)
- Die (27 mm) with fixing screw
- Die (16.3 mm) with fixing screw
- Specimen clamp with two fixing screws
- Hexagonal wrench, x2 (3 mm, 4 mm))
- Stop collar

Additional 1 kg weights are available as an optional extra - see “Spares and accessories” on page 20.

Kit G (Optional)

To meet the requirements of the following standards:

BS EN ISO 6272-2:2011

- Static indenter with handle and punch (15.9 mm)
- Static indenter with handle and punch (12.7 mm)
- Weight with handle (1 kg)
- Die (16.3 mm) with fixing screw
- Guide bracket with two fixing screws
- Hexagonal wrench, x 2 (3 mm, 4 mm)

Additional 1 kg weights are available as an optional extra - see “Spares and accessories” on page 20.

2 GETTING STARTED

This section of the instructions is intended for first-time users of the Elcometer 1615 Variable Impact Tester. It contains information on the parts, installation and adjustment of the instrument. When you have finished reading this section you will be ready to start using your Elcometer 1615 Variable Impact Tester.

2.1 Identifying the parts

1. Base plate with:
 - Die mounting hole
 - Die fixing hole, threaded
 - Table mounting holes
2. Guide tube supporting arm with:
 - Clamp
 - Bubble level
 - Weight stop collar fixing pin
 - Sample clamp holes, (fitted with blanking pieces)
 - Guide tube. The guide tube is engraved with two scales - one in kg-cm and the other in lb-inch. Use whichever scale is appropriate for the test kit and standard to which you are testing.

Note: *The scales engraved on the guide tube are correct when using a weight of 1kg or 1lb. If additional or different weights are used the scale must be corrected to suit. (eg: a scale reading of 10lb-inch is corrected to 20lb-inch when using a 2lb weight).*

3. Release collar.

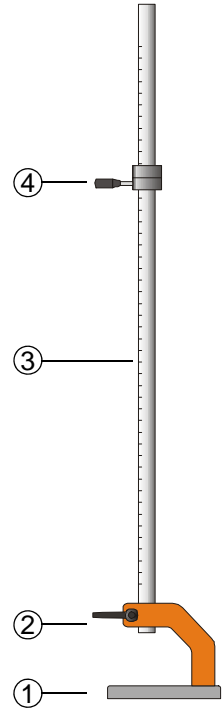

2.2 Mounting the instrument

Mount the instrument on a sturdy table. For maximum rigidity, place the instrument directly above one of the legs of the table. Use the built-in bubble level to ensure the instrument base is horizontal.

Fasten the instrument in place using suitable fixings and the two table mounting holes in the base plate.

2.3 Adjusting the guide tube

1. Raise the indenter by lifting its handle.
2. Place the specimen on the die and clamp in place by rotating the specimen clamp (if fitted to your tester).
3. Lower the indenter gently until the punch rests on the specimen.
4. Check that the centre of the handle of the falling weight is aligned with the 0 (zero) engraved line on the guide tube scale. If adjustment is required :
 - Unscrew the guide tube clamp.
 - Adjust the position of the guide tube until a correct zero is obtained.
 - If your tester is fitted with a stop collar, also ensure that the slot in the guide tube is aligned with the notches in the stop collar.
 - Tighten the guide tube clamp.

3 ASSEMBLING THE PARTS

Note: Your test kit may not include all the parts listed below.

1. Die

Place die (1) into hole in base plate and fix in place using the screw provided in the kit of parts (1a).

2. Specimen clamp

Position specimen clamp (2) under guide tube supporting arm and fix in place using the two screws (2a) provided in the kit of parts (remove blanking plugs first if necessary).

3. Stop collar

Slide top collar (3) onto guide tube and engage with locating pin on base.

4. Release collar

Slide release collar (4) onto guide tube and then tighten fixing screw (4a).
*Note: Fit this item **after** inserting the indenter, and any weights required.*

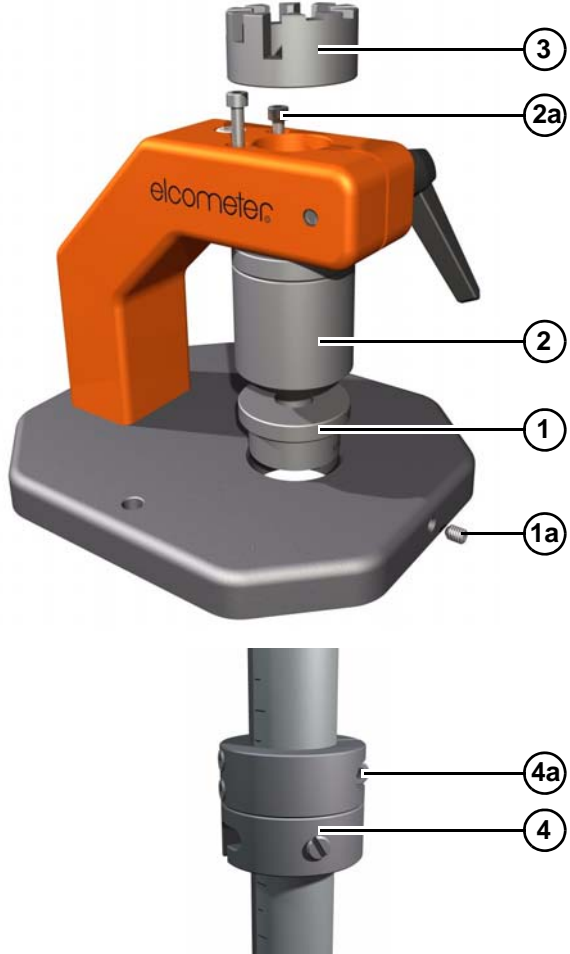

5. Guide bracket

Position guide bracket (5) under guide tube supporting arm and fix in place using the two screws (2a) provided in the kit of parts (remove blanking plugs first if necessary).

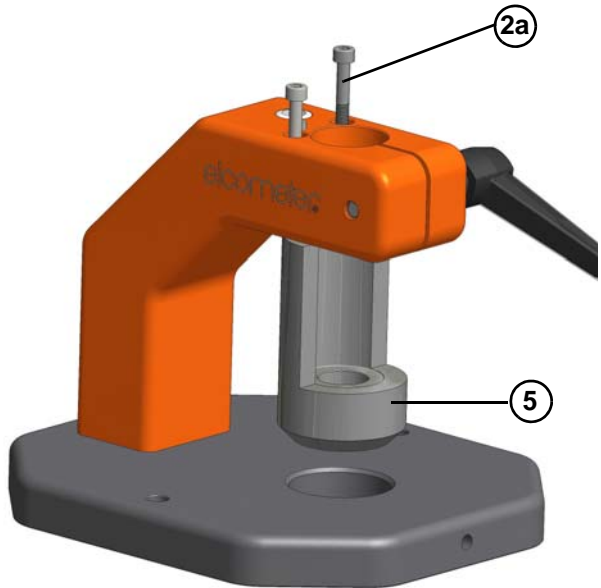

4 ASSEMBLING THE KITS

Before assembling any of the test kits, first check that the guide tube is positioned correctly in the guide tube supporting arm clamp and adjust if necessary - see “Adjusting the guide tube” on page 9. Remove the weight release collar before starting.

For guidance on how to fit the parts see “Assembling the parts” on page 10.

4.1 Assembling Kit A

1. Fit die into base.
2. Fit specimen clamp onto base.
3. Fit stop collar onto base.
4. If required, add additional weight(s) to the indenter and tighten fixing screw(s).
5. Slide indenter down inside guide tube until it reaches the bottom of the tube.
6. Fit release collar onto guide tube.

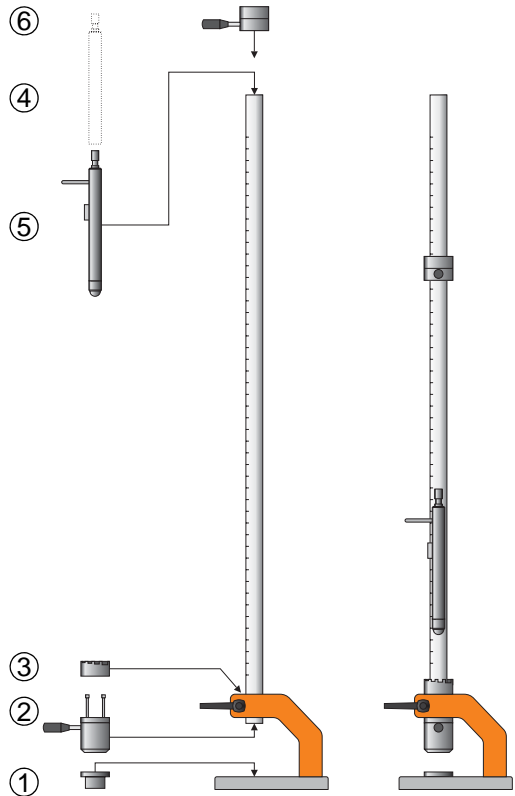

4.2 Assembling Kit B

1. Fit die into base.
2. Slide indenter down inside guide tube until it reaches the bottom of the tube.
3. Slide weight down inside guide tube until it rests on the top of the indenter.
4. Fit release collar onto guide tube.

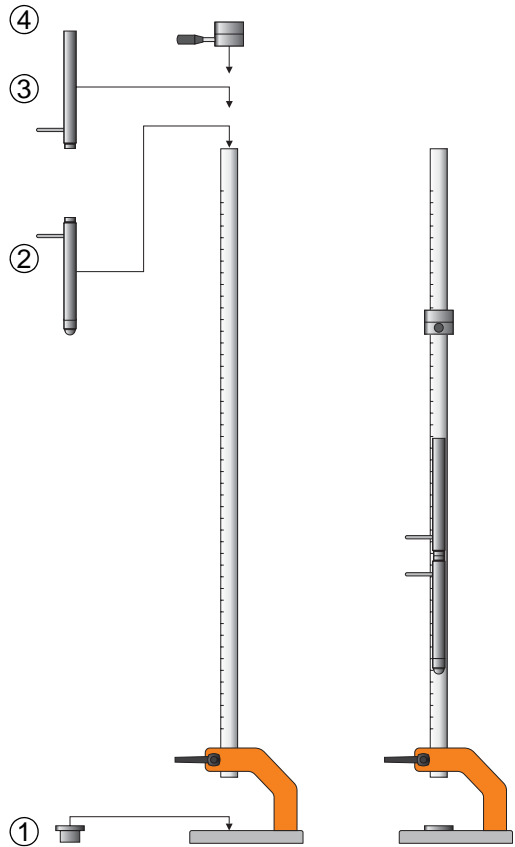

Kit B is supplied with the 15.9 mm punch already fitted to the indenter and the 12.7 mm punch loose for the user to fit as required.

To fit the punch, insert the punch (1) into the hole in the end of the indenter and fix in place using the screw (1a) provided with the kit.

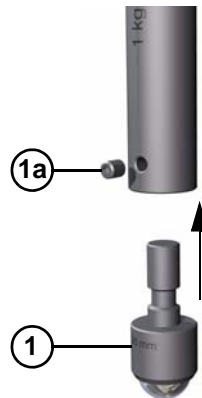

4.3 Assembling Kit C

Follow the instructions given for Kit B.

4.4 Assembling Kit D

Follow the instructions given for Kit A.

4.5 Assembling Kit E

1. Fit die into base.
2. Slide indenter down inside guide tube until it reaches the bottom of the tube.
3. Fit release collar onto guide tube.

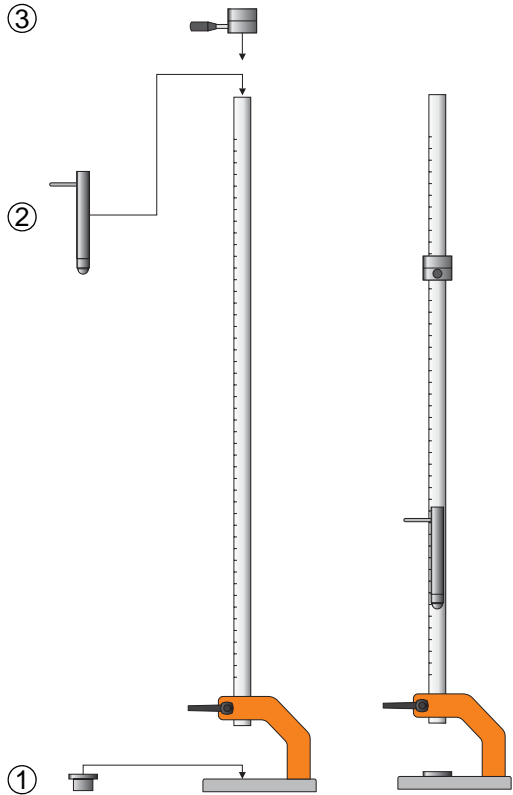

4.6 Assembling Kit F

Follow the instructions given for Kit A or Kit B, depending upon the test standard.

Note: Remember to fit the correct die for the test :

- | | |
|---|------------------------|
| • Falling indenter/punch (20mm) | Use 27mm die (Kit A) |
| • Falling weight + static indenter/punch (15.9mm or 12.7mm) | Use 16.3mm die (Kit B) |

4.7 Assembling Kit G

1. Fit die into base.
2. Fit guide bracket to base.
3. Place static indenter (15.9 mm or 12.7 mm) into guide bracket.
4. Slide weight down inside guide tube until it rests on the static indenter.
5. Fit release collar onto guide tube.

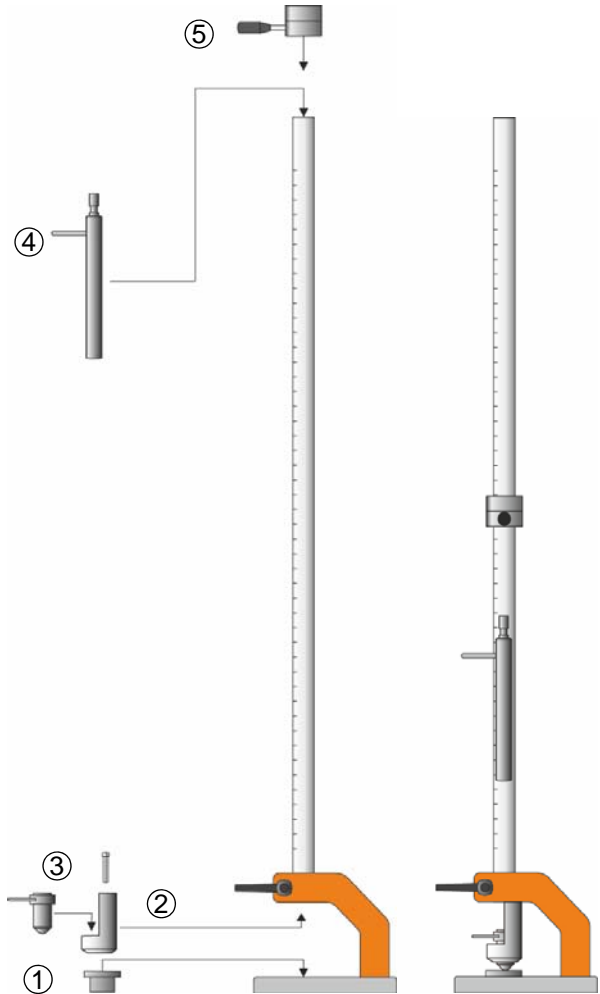

5 TESTING A SPECIMEN

5.1 Test procedure using Kit A

1. Slide release collar to required position on the scale and lock in position by tightening fixing screws.

Note: *The bottom edge of the release collar must be set to the required height minus 1 cm.*

2. Lift indenter up to release collar and lock into position by rotating handle on release collar.
3. Place specimen on die.
4. Clamp specimen onto die by lowering specimen clamp (rotate handle).
5. Lift and rotate stop collar until depth required is aligned with slot in guide tube and then lower onto locating pin on base.
6. Release indenter by rotating handle on release collar.
7. After impact, release specimen clamp, lift indenter and remove specimen.
8. Inspect paint surface using 10x magnifier supplied to check for elongation, cracking or peeling of the paint surface.

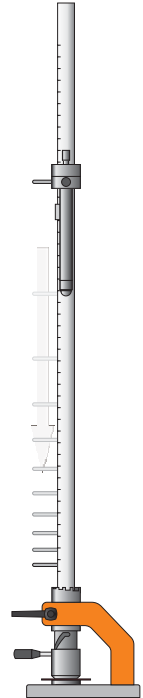

5.2 Test procedure using Kit B

1. Slide release collar to required position and lock in position by tightening fixing screws.

Note: *The bottom edge of the weight release collar must be set to the required height minus 1 cm.*

2. Lift weight up to release collar and lock into position by rotating handle on release collar.

Note: Do not lift the *indenter* up the guide tube - only lift the *weight*.

3. Raise indenter, place specimen on die and then lower indenter gently until punch touches surface of specimen.
4. Release weight by rotating handle on release collar.
5. After impact, lift indenter and weight and remove specimen.
6. Inspect paint surface using 10x magnifier supplied to check for elongation, cracking or peeling of the paint surface.

Depending upon test requirements, the surface can also be tested using a pinhole detector - see "Related equipment" on page 22.

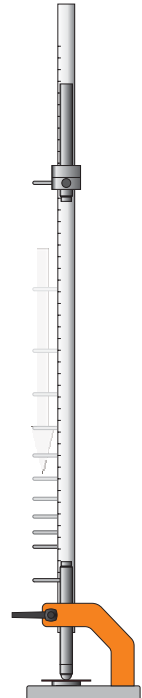

5.3 Test procedure using Kit C

Follow the instructions given for Kit B.

5.4 Test procedure using Kit D

Follow the instructions given for Kit A.

5.5 Test procedure using Kit E

1. Slide release collar to required position and lock in position by tightening fixing screws.

Note: *The bottom edge of the weight release collar must be set to the required height minus 1 cm.*

2. Lift indenter up to release collar and lock into position by rotating handle on release collar.
3. Place specimen on die.
4. Release indenter by rotating handle on release collar.
5. After impact, lift indenter and remove specimen.
6. Inspect paint surface using 10x magnifier supplied to check for elongation, cracking or peeling of the paint surface.

5.6 Test procedure using Kit F

Follow the instructions given for Kit A or Kit B, depending upon the test standard.

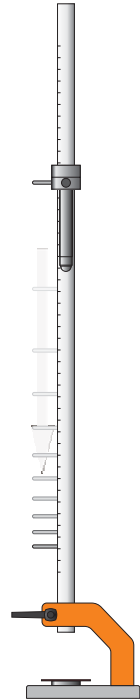

5.7 Test procedure using Kit G

1. Slide release collar to required position and lock in position by tightening fixing screws.

Note: *The bottom edge of the weight release collar must be set to the required height minus 1 cm.*

2. Lift weight up to release collar and lock into position by rotating handle on release collar.
3. Raise indenter, place specimen on die and then lower indenter gently until punch touches surface of specimen.
4. Release weight by rotating handle on release collar.
5. After impact, lift indenter and weight and remove specimen.
6. Inspect paint surface using 10x magnifier supplied to check for elongation, cracking or peeling of the paint surface.



6 MAINTENANCE

The Elcometer 1615 Variable Impact Tester is designed to give many years reliable service under normal operating and storage conditions.

The Elcometer 1615 Variable Impact Tester does not contain any user-serviceable components. In the unlikely event of a fault, the instrument should be returned to your local Elcometer supplier or directly to Elcometer.

Details of Elcometer offices around the world are given on the outside cover of these Operating Instructions. Alternatively visit the Elcometer website, www.elcometer.com

7 TECHNICAL SPECIFICATION

Guide tube, scale length: 0 cm to 100 cm (0" to 39")
 total length: 1.39 m (54")
 Dimensions: 1460 mm x 200 mm x 165 mm (57.5" x 8" x 6.5")
 Weight (tester only): 11 kg (24 lb)

8 SPARES AND ACCESSORIES

The following spare parts and optional accessories are available from your local supplier or direct from Elcometer:

Kit A

- Kit A complete KT001615KITA
- Punch (20 mm), Outside Diameter: 25mm KT001615N226
- Die (27 mm) with fixing screw and hexagonal wrench KT001615N214
- Specimen clamp with two fixing screws KT001615N209
- Stop collar KT001615N208
- Additional 1 kg weight, Outside Diameter: 25mm KT001615N221

Kit B

- Kit B complete KT001615KITB
- Punch (12.7 mm) KT001615N215
- Punch (15.9 mm) KT001615N205
- Die (16.3 mm) with fixing screw and hexagonal wrench KT001615N212

Kit C

- Kit C complete KT001615KITC
- Punch (15.9 mm) KT001615N205
- Die (16.3 mm) with fixing screw and hexagonal wrench KT001615N212

Kit D

- Kit D complete KT001615KITD
- Punch (20 mm), Outside Diameter: 24.6mm KT001615N206

- Die (27 mm) with fixing screw and hexagonal wrench KT001615N214
- Specimen clamp with two fixing screws KT001615N209
- Stop collar KT001615N208
- Additional 1 kg weight, Outside Diameter: 24.6mm KT001615N201

Kit E

- Kit E complete KT001615KITE
- Punch (23 mm) KT001615N207
- Die (22 mm) with fixing screw and hexagonal wrench KT001615N213

Kit F

- Kit A complete plus Kit B complete KT001615KITF
- Punch (20 mm), Outside Diameter: 25mm KT001615N226
- Punch (15.9 mm) KT001615N205
- Punch (12.7 mm) KT001615N215
- Die (27 mm) with fixing screw and hexagonal wrench KT001615N214
- Die (16.3 mm) with fixing screw and hexagonal wrench KT001615N212
- Specimen clamp with two fixing screws KT001615N209
- Stop collar KT001615N208
- Additional 1 kg weight, Outside Diameter: 25mm KT001615N221

Kit G

- Kit G complete KT001615KITG
- Static indenter (15.9 mm) KT001615N217
- Static indenter (12.7 mm) KT001615N216
- Falling Weight 1 kg, Outside Diameter: 25mm KT001615N231
- Die (16.3 mm) with fixing screw KT001615N232
- Guide bracket with two fixing screws & hexagonal wrench KT001615N301
- Additional 1 kg weight, Outside Diameter: 25 mm KT001615N221

