

# **Elcometer 1615**

## **Variable Impact Tester - Kit of Parts -**

### **Operating Instructions**

elcometer® is a registered trademark of Elcometer Limited.  
All other trademarks acknowledged.

© Copyright Elcometer Limited. 2010 - 2024.

All rights reserved. No part of this Document may be reproduced, transmitted, transcribed, stored (in a retrieval system or otherwise) or translated into any language, in any form or by any means (electronic, mechanical, magnetic, optical, manual or otherwise) without the prior written permission of Elcometer Limited.

A copy of this Instruction Manual is available for download on our Website via [www.elcometer.com](http://www.elcometer.com)

## CONTENTS

---

Section	Page
1 About this kit of parts .....	2
2 Adjusting the guide tube of the basic tester .....	6
3 Fitting the parts onto the basic tester .....	7
4 Assembling the kits .....	9
5 Spares and accessories .....	15

Thank you for purchasing this kit of parts for your Elcometer 1615 Variable Impact Tester. Welcome to Elcometer.

Elcometer are world leaders in the design, manufacture and supply of inspection equipment for coatings and concrete. Our products cover all aspects of coating inspection, from development through application to post application inspection.

Your Elcometer 1615 Variable Impact Tester is a world beating product. With the purchase of this kit of parts you now have access to the worldwide service and support network of Elcometer. For more information visit our website at [www.elcometer.com](http://www.elcometer.com)

## 1 ABOUT THIS KIT OF PARTS

---

The Elcometer 1615 Variable Impact Tester is used to evaluate the resistance of a coating to impact (elongation, cracking or peeling).

The coated specimen is placed on top of a die and impact between the specimen and a hemispherical punch is produced by means of a falling weight. The specimen is removed from the tester and the damage to the coating caused by the rapid deformation of the metal is evaluated.

This kit of parts will enable the tester to be used in accordance with one or more of the test standards listed in section 1.1 on page 3.

The appropriate kit of parts must be ordered in addition to the basic tester. These instructions describe how to *assemble* the kit of parts onto the basic tester. For instruction on how to *use* the kit of parts, please refer to the separate operating instructions supplied with the tester (operating instructions for all Elcometer products can be downloaded from our Website via [www.elcometer.com](http://www.elcometer.com)).

***To maximise the benefits of this kit of parts please take some time to read these Operating Instructions. Do not hesitate to contact Elcometer or your Elcometer supplier if you have any questions.***

## 1.1 WHAT THE BOX CONTAINS

Kit	For testing to standard	Box contents
A	ISO 6272:1993 EN 13523-5:2001 JIS K 5600-5-3:1999 DIN EN ISO 6272-1:2004 SN EN ISO 6272-1:2004 ÖNORM EN ISO 6272-1:2006	<ul style="list-style-type: none"> <li>• Falling indenter with handle, stop key and a punch (20 mm) (total mass = 1 kg).</li> <li>• Die (27 mm) with fixing screw</li> <li>• Specimen clamp with two fixing screws</li> <li>• Stop collar</li> </ul> <p>Additional 1 kg weights are available as an optional extra - see "Spares and accessories" on page 16.</p>
B	ISO 6272-2:2002 ASTM D 2794:2004 QUALICOAT:2006 BS EN ISO 6272-2:2004	<ul style="list-style-type: none"> <li>• Weight with handle (1 kg)</li> <li>• Static indenter with handle and punch (15.9 mm)</li> <li>• Punch (12.7 mm)</li> <li>• Die (16.3 mm) with fixing screw</li> <li>• Hexagonal wrench (3 mm)</li> </ul>
C	EN 12206-1:2004 BS6496:1984 ASTM D 2794:2004	<ul style="list-style-type: none"> <li>• Weight with handle (2 lb)</li> <li>• Static indenter with handle and punch (15.9 mm)</li> <li>• Die (16.3 mm) with fixing screw</li> <li>• Hexagonal wrench (3 mm)</li> </ul>

Kit	For testing to standard	Box contents
D	ISO 6272-1:2002 BS EN ISO 6272-1:2004	<ul style="list-style-type: none"><li>• Falling indenter with handle, stop key and punch (20 mm) (total mass = 1 kg).</li><li>• Die (27 mm) with fixing screw</li><li>• Specimen clamp with two fixing screws</li><li>• Hexagonal wrench, x2 (3 mm, 4 mm))</li><li>• Stop collar</li></ul>
E	NF T30-017:1989	<ul style="list-style-type: none"><li>• Falling indenter with handle and punch (23 mm) (total mass = 400 g).</li><li>• Die (22 mm) with fixing screw</li><li>• Hexagonal wrench (3 mm)</li></ul>

Kit	For testing to standard	Box contents
F	ISO 6272:1993 EN 13523-5:2001 JIS K 5600-5-3:1999 DIN EN ISO 6272-1:2004 SN EN ISO 6272-1:2004 ÖNORM EN ISO 6272-1:2006 ISO 6272-2:2002 ASTM D 2794:2004 QUALICOAT:2006 BS EN ISO 6272-2:2004 ISO 6272-1:2011	<ul style="list-style-type: none"> <li>• Falling indenter with handle, stop key and a punch (20 mm) (total mass = 1 kg).</li> <li>• Weight with handle (1 kg)</li> <li>• Static indenter with handle and punch (15.9 mm)</li> <li>• Punch (12.7 mm)</li> <li>• Die (27 mm) with fixing screw</li> <li>• Die (16.3 mm) with fixing screw</li> <li>• Specimen clamp with two fixing screws</li> <li>• Hexagonal wrench, x2 (3 mm, 4 mm)</li> <li>• Stop collar</li> </ul> <p>Additional 1 kg weights are available as an optional extra - see "Spares and accessories" on page 16.</p>

## 2 ADJUSTING THE GUIDE TUBE OF THE BASIC TESTER

---

1. Raise the indenter by lifting its handle.
2. Place the specimen on the die and clamp in place by rotating the specimen clamp (if fitted to your tester).
3. Lower the indenter gently until the punch rests on the specimen.
4. Check that the centre of the handle of the falling weight is aligned with the 0 (zero) engraved line on the guide tube scale. If adjustment is required :
  - Unscrew the guide tube clamp.
  - Adjust the position of the guide tube until a correct zero is obtained.
  - If your tester is fitted with a stop collar, also ensure that the slot in the guide tube is aligned with the notches in the stop collar.
5. Tighten the guide tube clamp.

### 3 FITTING THE PARTS ONTO THE BASIC TESTER

**Note:** Your test kit may not include all the parts listed below.

#### 1. Die

Place die (1) into hole in base plate and fix in place using the screw provided in the kit of parts (1a).

#### 2. Specimen clamp

Position specimen clamp (2) under guide tube supporting arm and fix in place using the two screws (2a) provided in the kit of parts (remove blanking plugs first if necessary).

#### 3. Stop collar

Slide stop collar (3) onto guide tube and engage with locating pin on base.

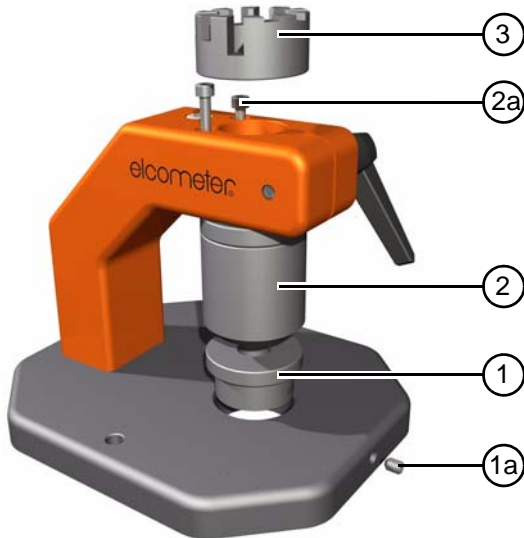

#### 4. Guide Bracket

Position guide bracket (4) under guide tube supporting arm and fix in place using the two screws (2a) provided in the kit of parts (remove blanking plugs first if necessary)

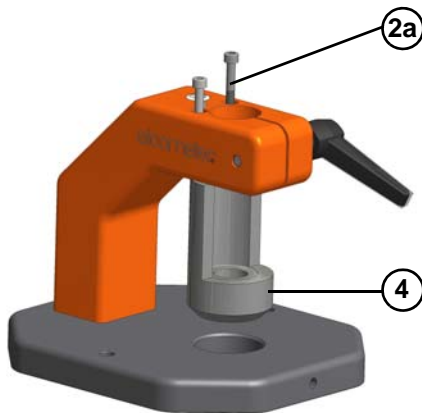

## 5. Release collar

Slide release collar (5) onto guide tube and then tighten fixing screw (5a). *Note: Fit this item **after** inserting the indenter and any weights required.*

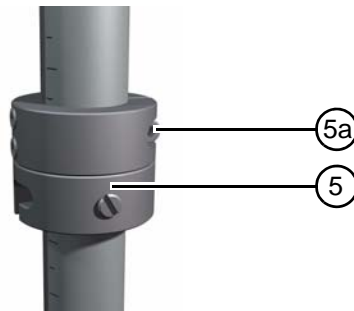

## 4 ASSEMBLING THE KITS

---

Before assembling any of the test kits, first check that the guide tube is positioned correctly in the guide tube supporting arm clamp and adjust if necessary - see “Adjusting the guide tube of the basic tester” on page 6. Remove the release collar before starting.

For guidance on how to fit the parts see “Fitting the parts onto the basic tester” on page 7.

#### 4.1 ASSEMBLING KIT A

1. Fit die into base.
2. Fit specimen clamp onto base.
3. Fit stop collar onto base.
4. If required, add additional weight(s) to indenter and tighten fixing screw(s).
5. Slide indenter down inside guide tube until it reaches the bottom of the tube.
6. Fit release collar onto guide tube.

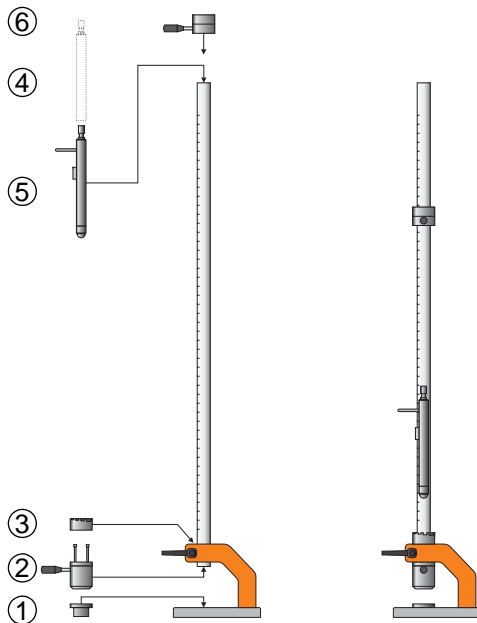

## 4.2 ASSEMBLING KIT B

1. Fit die into base.
2. Slide indenter down inside guide tube until it reaches the bottom of the tube.
3. Slide weight down inside guide tube until it rests on the top of the indenter.
4. Fit release collar onto guide tube.

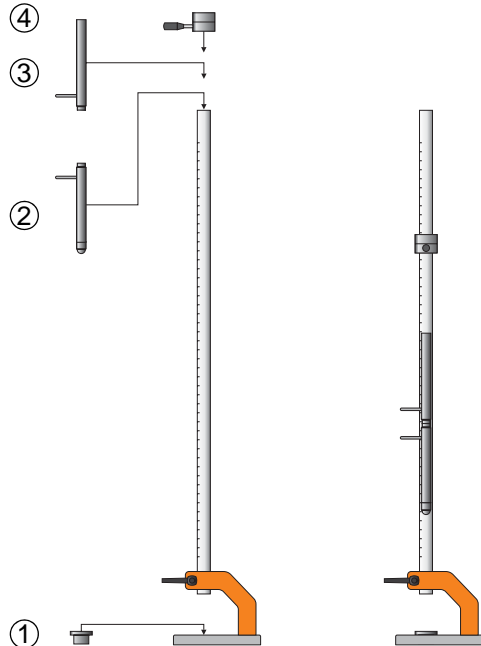

Kit B is supplied with the 15.9 mm punch already fitted to the indenter and the 12.7 mm punch loose for the user to fit as required.

To fit the punch, insert the punch (1) into the hole in the end of the indenter and fix in place using the screw (1a) provided with the kit.

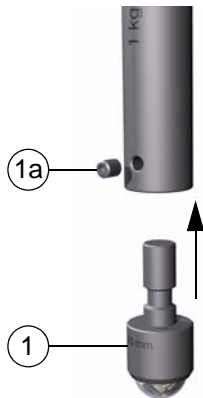

#### 4.3 ASSEMBLING KIT C

Follow the instructions given for Kit B.

#### 4.4 ASSEMBLING KIT D

Follow the instructions given for Kit A.

#### 4.5 ASSEMBLING KIT E

1. Fit die into base.
2. Slide indenter down inside guide tube until it reaches the bottom of the tube.
3. Fit release collar onto guide tube.

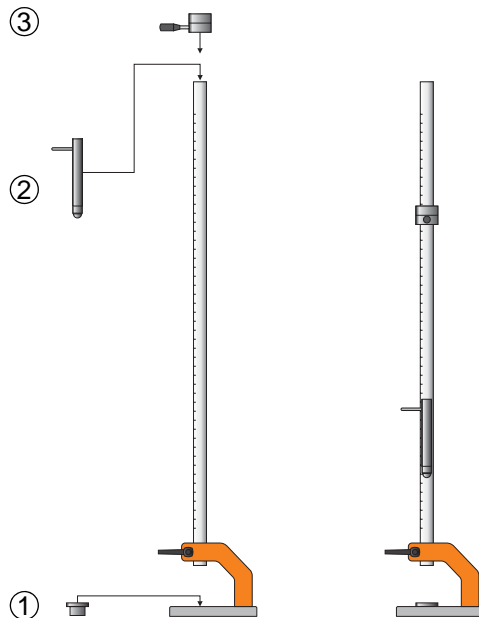

#### 4.6 ASSEMBLING KIT F

Follow the instructions given for Kit A or Kit B, depending upon the test standard.

**Note:** *Remember to fit the correct die for the test :*

- Falling indenter/punch (20mm) Use 27mm die (Kit A)
- Falling weight + static indenter/punch (15.9mm or 12.7mm) Use 16.3mm die (Kit B)

## 5 SPARES AND ACCESSORIES

---

The following spare parts and optional accessories are available from your local supplier or direct from Elcometer:

### Kit A

- |  |              |
|--|--------------|
| • Kit A complete                                     | KT001615KITA |
| • Punch (20 mm), Outside Diameter: 25mm              | KT001615N226 |
| • Die (27 mm) with fixing screw and hexagonal wrench | KT001615N214 |
| • Specimen clamp with two fixing screws              | KT001615N209 |
| • Stop collar  | KT001615N208 |
| • Additional 1 kg weight, Outside Diameter: 25mm     | KT001615N221 |

### Kit B

- |  |              |
|--|--------------|
| • Kit B complete                                       | KT001615KITB |
| • Punch (12.7 mm)                                      | KT001615N215 |
| • Punch (15.9 mm)                                      | KT001615N205 |
| • Die (16.3 mm) with fixing screw and hexagonal wrench | KT001615N212 |

**Kit C**

- Kit C complete KT001615KITC
- Punch (15.9 mm) KT001615N205
- Die (16.3 mm) with fixing screw and hexagonal wrench KT001615N212

**Kit D**

- Kit D complete KT001615KITD
- Punch (20 mm), Outside Diameter: 24.6mm KT001615N206
- Die (27 mm) with fixing screw and hexagonal wrench KT001615N214
- Specimen clamp with two fixing screws KT001615N209
- Stop collar KT001615N208
- Additional 1 kg weight, Outside Diameter: 24.6mm KT001615N201

**Kit E**

- Kit E complete KT001615KITE
- Punch (23 mm) KT001615N207
- Die (22 mm) with fixing screw and hexagonal wrench KT001615N213

## Kit F

- Kit A complete plus Kit B complete KT001615KITF
- Punch (20 mm), Outside Diameter: 25 mm KT001615N226
- Punch (15.9 mm) KT001615N205
- Punch (12.7 mm) KT001615N215
- Die (27 mm) with fixing screw and hexagonal wrench KT001615N214
- Die (16.3 mm) with fixing screw and hexagonal wrench KT001615N212
- Specimen clamp with two fixing screws KT001615N209
- Stop collar KT001615N208
- Additional 1 kg weight, Outside Diameter: 25mm KT001615N221

